

THE



X

Kiss Inline Backflushing Goodbye



**Ideal for chemical,
desalinization,
sewage,
and other
severe applications**



SERIES

Crispin





No Downtime. No Hassles.

With the X Series, all that stands between you and a clean valve is one wrench, two bolts and a clamp.

Available in Air & Vacuum, Pressure Air Release and Combination assemblies, the valve features our exclusive Head Exchange System, with its head-fixed stainless steel valve internals. To clean, simply loosen the head assembly, which is sealed in place by a sanitary stainless clamp fitting. Pull out the original head, which weighs less than 10lbs, and pop in a spare. Then clean the original internals at your leisure. Each of the valve heads are color-coded by type so that they are easily identifiable on the shelf, and during head exchange.

All of the valve heads fit the same practically indestructible 316 stainless steel body. One-third the weight of a standard cast iron body, it also features a polished interior that eliminates buildup, because debris has nothing to cling to. All Crispin valves are tested to the latest ANSI/AWWA C512 standards.

The Head Exchange System

The new Crispin X Series brings valve maintenance into the 21st century. All of the valve parts are stainless steel, making them impervious to rust. Instead of a bolted, flanged connection, the X series features a stainless circular clamp to secure the valve head to the body for the industry's tightest seal.

All valve internals are affixed to the head, which comes in three color-coded configurations—red for the Air & Vacuum valve; green for the Pressure Air Release valve; and blue for the Universal Combination valve. The packaging for each is also color-coded for convenient storage.

When backflushing is needed on an inline X Series valve, the spare head is put to immediate use, replacing the original valve head so that proper cleaning can take place off-site in a safer and more sanitary environment.

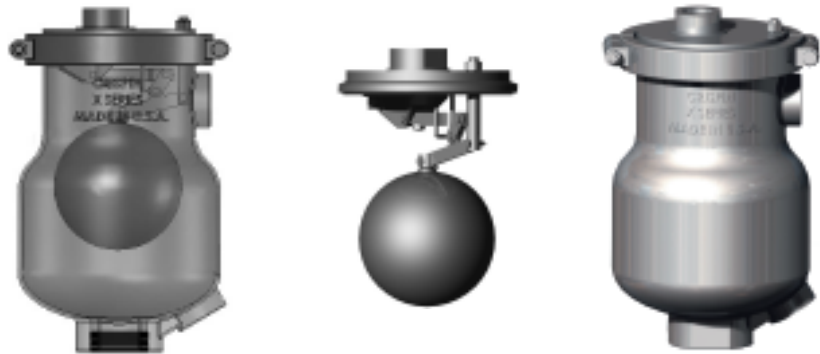

UNIVERSAL COMBINATION X SERIES: 2" X 1" (UX20)

ITEM #	PART	MATERIAL	QTY.
1	Cover Flange, 2" x 1" Universal	A276 Type 316 S.S.	1
2	Hex Nut	Type 316 S.S.	1
3	Valve Lever	A276 Type 316 S.S.	1
4	Lever Fulcrum	A240 Type 316 S.S.	2
5	Seat Cage	A240 Type 316 S.S.	1
6	SBHC Screw	Type 316 S.S.	2
7	Pressure Seat	A582 Type 316 S.S.	1
8	Ball Fulcrum	A276 Type 316 S.S.	1
9	Fulcrum	Type 316 S.S.	1
10	Ball Lever	A240 Type 316 S.S.	1
11	Link	A240 Type 316 S.S.	2
12	Valve Plunger	Buna-N Rubber/Type 316 S.S.	1
13	Hex Nut	Type 316 S.S.	1
14	Seat	Buna-N Rubber	1
15	Top	A276 Type 316 S.S.	1
16	Float	A240 Type 316 S.S.	1
17	Limit Stop	Type 316 S.S.	5
18	Hex Nut	Type 316 S.S.	1
19	Bearing Pin	A582 Type 316 S.S.	2
20	Bearing Pin	A582 Type 316 S.S.	2
21	Bearing Pin	A582 Type 316 S.S.	1
22	Bearing Pin	A582 Type 316 S.S.	1
23	Cotter Pin	A582 Type 316 S.S.	6
24	TC Ferrule Clamp	Type 316 S.S.	1
25	2" Valve Body	A351 CF8M, Type 316 S.S.	1
26	Gasket	Buna-N Rubber	1

No Downtime. No Hassles.

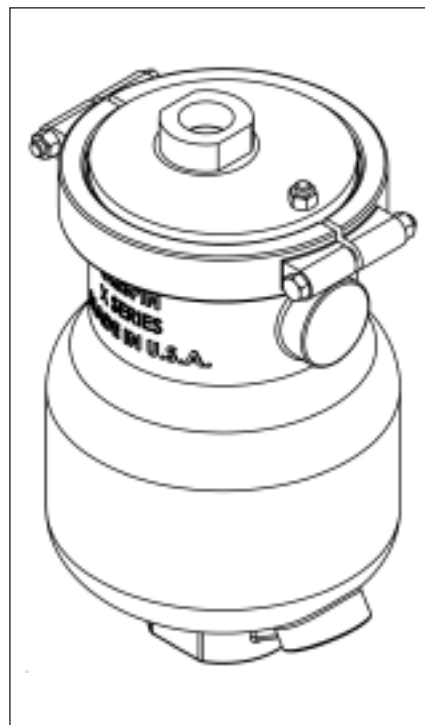
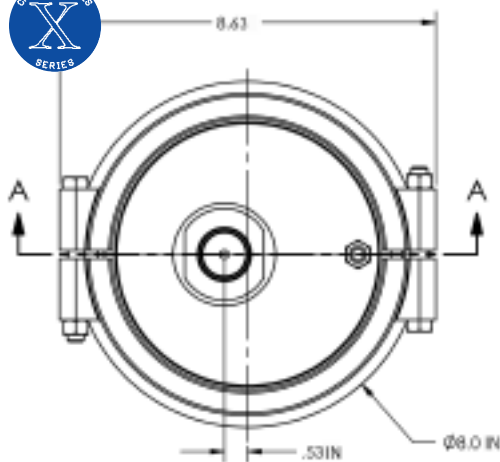
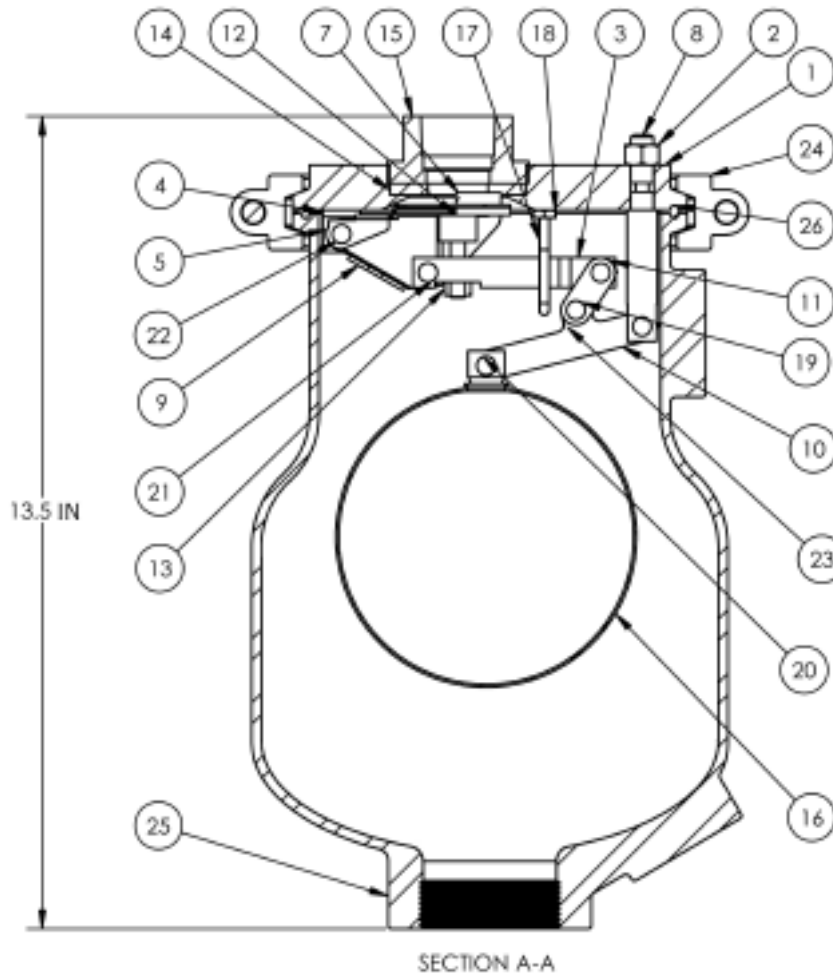

Specification For UX Series

The following specification is for the Universal Combination Series. For Air & Vacuum and Pressure Air Release X Series valve specifications, contact the factory.

1. Combination air valves shall be heavy-duty "Universal" style single body units incorporating the functions of an air and vacuum valve with an air release valve in a single housing.

2. Combination air valves shall release accumulations of air at high points within a pipeline by exhausting large volumes of air as the pipeline is being filled, and then by releasing accumulated pockets of air while the pipeline is in operation and under pressure. Combination air valves shall also be designed to permit large volumes of air to enter the pipeline during pipeline drainage.

3. The valve body and cover flange shall be cast or fabricated 316 stainless steel and shall incorporate a "sanitary clamp" to attach the flange to the body at the outlet. Valves that use traditional bolting to attach the cover flange to the body are not acceptable. The flange clamp must be located at the outlet of the body for ease of cleaning and maintenance. Other clamping locations are not acceptable.

4. All non-sealing internal metal components shall be 316 s.s. No plastic, nylon, or fiberglass components will be acceptable.

5. The valve shall incorporate an Air Release orifice of 3/16" for use at 200 psig. No deviation from this orifice size will be allowed. This orifice will be located in the outlet of the valve and shall be drilled in a 316 s.s. orifice plate that seals against a Buna-N rubber seat. Valves with seals that flex or "roll" will not be acceptable.

6. Unit may have a maximum height of 14 inches and a maximum weight of 28 lbs.

7. The valve shall be Crispin "X" Series, model #UX20 (2" x 1") or approved equal.

ORIFICE DATA

Orifice Diameter3/16"
 Max. Working Pressure200 PSIG

1. Inlet Size: 2" NPT. Outlet Size: 1" NPT.
2. Weight: 28 lbs
3. Tested in accordance with latest revision of AWWA C512

No Downtime. No Hassles.

PRESSURE AIR RELEASE X SERIES: 2" X 3/8" (PX20)

ITEM #	PART	MATERIAL	QTY.
1	2" Valve Body	A351 CF8M, Type 316 S.S.	1
2	Float	A240/A276 Type 316 S.S.	1
3	Fulcrum Assembly	A276/A240 Type 316 S.S.	1
4	Seat	A276 Type 316 S.S.	1
5	Valve Lever	A276 Type 316 S.S.	1
6	Float Rod	A276 Type 316 S.S.	1
7	Ball Lever	A276 Type 316 S.S.	1
8	Link	A240 Type 316 S.S.	2
9	Bearing Pin	A276 Type 316 S.S.	2
10	Bearing Pin	A276 Type 316 S.S.	1
11	SBHC Screw 0.25-20x0.5-HX-N	Type 316 S.S.	2
12	Hex Nut 0.25-28-D-N	Type 316 S.S.	1
13	Plunger	Buna-N Rubber/ Type 316 S.S.	1
14	Gasket	Buna-N Rubber	1
15	3/8 NPT Elbow	Type 316 S.S.	1
16	Cover Assembly	Type 316 S.S.	1
17	3/16 Retaining Clip	Type 316 S.S.	5
18	TC Ferrule Clamp	Type 316 S.S.	1

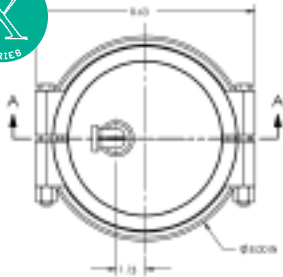
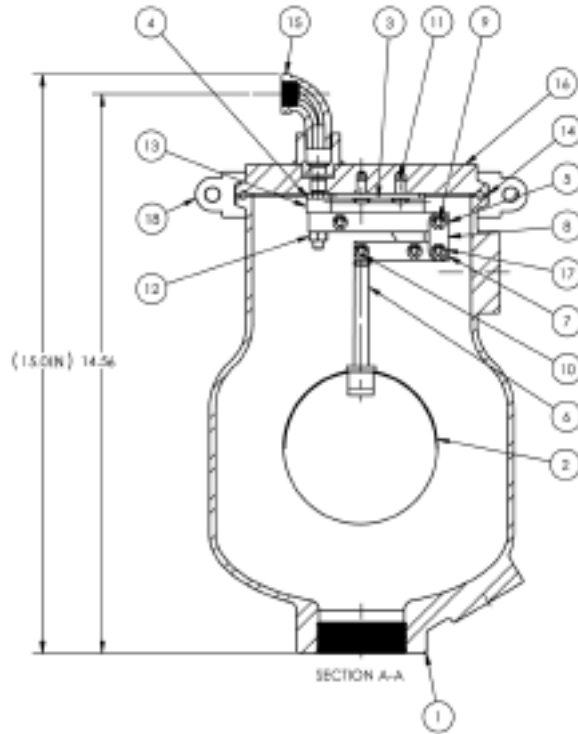

ORIFICE DATA

Orifice Diameter3/16"
Max. Working Pressure200 PSIG

1. Inlet Size: 2" NPT. Outlet Size: 3/8" NPT.
2. Weight: 29 lbs
3. Tested in accordance with latest revision of AWWA C512

AIR & VACUUM X SERIES: 2" X 1" (AX20)

ITEM #	PART	MATERIAL	QTY.
1	Flange	Type 316 S.S.	1
2	Top	A276 Type 316 S.S.	1
3	Seat	Buna-N-Rubber	1
4	Gasket	Buna-N-Rubber	1
5	Rod Guide Stand	A240 Type 316 S.S.	1
6	HHCS, 1/4-20 x .75	Type 316 S.S.	3
7	Float Rod Guide	A276 Type 316 S.S.	1
8	2" Valve Body	A351 CF8M Type 316 S.S.	1
9	Valve	Type 316 S.S.	1
10	Rod Guide Nut	A194 Type 316 S.S.	1
11	TC Ferrule Clamp	Type 316 S.S.	1
12	Stand Rod	Type 316 S.S.	3
13	Float	Type 316 S.S.	1

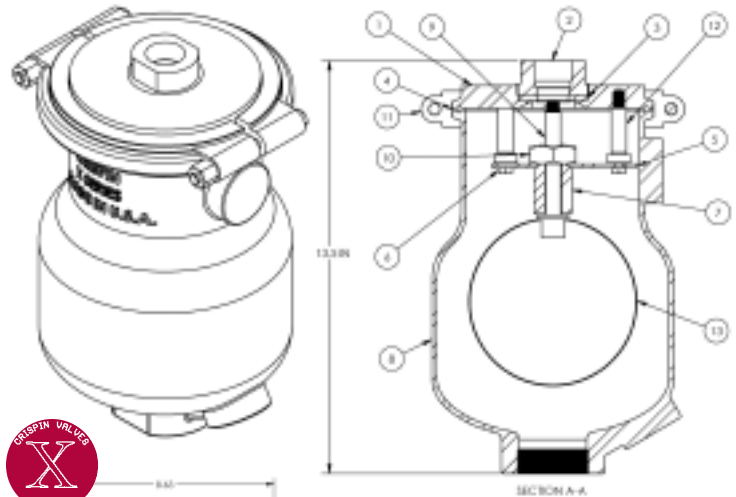

1. Inlet Size: 2" NPT. Outlet Size: 1" NPT
2. Weight: 30 lbs
3. Tested in accordance with latest revision of AWWA C512

* AX20 and UX20 (2" x 2") designs are also available.
Please contact the Crispin Valve at 800-247-VALV for more information.