

# The UL Series Universal Air Release Valves

---

Compound Lever System  
NPT Screwed or ANSI Class Flanges Available



**Crispin**  
Since 1905

---

Crispin Multiplex Manufacturing Co. • 600 Fowler Avenue • Berwick, PA 18603 • 1-800-247-VALV  
T: (570) 752-4524 • F: (570) 752-4962 • [www.crispinvalve.com](http://www.crispinvalve.com) • [info@crispinvalve.com](mailto:info@crispinvalve.com)



# UL SERIES

## Universal Air Release Valves

# Universal Air Release Valve

### Valve Function

- **Allows air to escape a pipeline as it is being filled**
- **Allows air to enter a pipeline as it is being emptied**
- **Allows accumulating air to escape while a line is in operation and under pressure**

### Features Include

- **Meets AWWA C-512**
- **Compound lever system**
- **NPT screwed or ANSI Class Flanges**

If accumulating air rises into the valve while the line is in operation and under pressure, it will displace the liquid at the top of the valve body and the float will drop as the liquid recedes. As this occurs, the pressure valve will open, permitting the escape of the accumulated air, after which the liquid level will rise and the valve will close.

Should the pipeline be drained through natural processes or should a large break develop, the float will drop all the way down as the liquid level drains from the valve body. The valve will then stay in the full open position permitting the entrance of air and eliminating the danger of pipeline collapse due to vacuum.

These cycles will repeat automatically as each condition presents itself, and the valve will function satisfactorily with hot or cold water, and in the presence of many chemicals and oilbase liquids.

### With Stainless Steel Trim or Bronze and Stainless Steel Trim

The Universal Air Valve is designed to permit the automatic escape of large quantities of air from a pipeline when the line is being filled, and to permit air to enter the pipeline when the line is being emptied. It also allows accumulating air to escape while the line is in operation and under pressure. This is accomplished with a compound lever system functioning in conjunction with a large and small orifice in one integral body casting.

As the liquid rises into the valve, air escapes through the large orifice to the atmosphere. Liquid entering the valve raises the float and lever system, carrying with it the pressure plunger and the main valve.

When the liquid has raised the float to its limit, the stainless steel main valve rests against the seat. The pressure plunger also rests against its seat, which is the main valve. In this position, the valve is closed and no liquid can escape.

### Model Information

Size of Valve	1"	2"	3"	4"
Model No.	UL10.1	UL20.1	UL30.1	UL40.1
Screwed Inlet	UL10	UL20	UL30	UL40
125# Flanged Inlet		UL21.1	UL31.1	UL41.1
250# Flanged Inlet		UL21	UL31	UL41
		UL22.1	UL32.1	UL42.1
		UL22	UL32	UL42

### Discharge in SCFM

Operating Pressure (PSIG)	ORIFICE SIZE				
	3/32"	1/8"	5/32"	3/16"	1/4"
150	13.8	24.4	37.9	54.6	98
200	17.9	31.9	49.5	72	127
250	22.1	39.2	61.1	88	157
300	26.4	46.7	73	105	187

### Orifice Sizing Information

Valve Size	MAXIMUM OPERATING PRESSURE IN PSI			
	Max. 150	Max. 200	Max. 250	Max. 300
1"	3/16"	3/32"	3/32"	3/32"
2"	1/4"	3/16"	3/16"	1/8"
3"	1/4"	3/16"	3/16"	1/8"
4"	1/4"	3/16"	3/16"	1/8"
6"	1/4"	3/16"	3/16"	1/8"
8"	1/4"	3/16"	3/16"	1/8"

For 6" and 8" dimension and weight information, see the following page.



# UL SERIES

## Universal Air Release Valve

### Universal Valves

#### Parts List: 1"-4" Valves

PART NO.	ITEM	MATERIAL
1P*	PROTECTOP	Cast Iron
1S*	TOP	Cast Iron
2	FLANGE	Cast Iron
3*	BODY, SCREWED	Cast Iron
3F*	BODY, 125 LB FLG.	Cast Iron
3FH*	BODY, 250 LB FLG	Cast Iron
4	A&V FULCRUM	Stainless Steel
5&16	PRESSURE FULCRUM	Stainless Steel
6	VALVE LEVER	Stainless Steel
7	LINK	Stainless Steel
8	BALL LEVER	Stainless Steel
9	BALL FLOAT	Stainless Steel
10	BALL FULCRUM	Stainless Steel
13	NUT	Stainless Steel
14	PRESSURE VALVE PLUNGER	Rubber/S/S
15	PRESSURE SEAT	Stainless Steel
17	SEAT CAGE	Stainless Steel
18	A&V SEAT	Rubber
21	PRESS LIMIT STOP	Stainless Steel
23	BEARING PIN	Stainless Steel
23A	BEARING PIN	Stainless Steel
24	BEARING PIN	Stainless Steel
25	BEARING PIN	Stainless Steel
26	PIN CLIP	Stainless Steel
28	SCREW	Stainless Steel
29	DRAIN PLUG	Steel
30	FULCRUM WASHER	Fibre
31	FULCRUM WASHER	Fibre
32	FLANGE GASKET	Armstrong
33	FLANGE BOLT	Steel
34	FLANGE NUT	Steel
35	A&V FULCRUM NUT	Steel
36	BALL FULCRUM NUT	Steel

#### Dimensions and Weights

MODEL	INLET	TRIM	HEIGHT	WIDTH	LENGTH	WT(LBS)
UL10	1" NPT	S/S	10 1/4"	6 7/8"	9 3/4"	27
UL10.1	1" NPT	S/S/BRASS	10 1/4"	6 7/8"	9 3/4"	27
UL20	2" NPT	S/S	13 1/2"	8 3/8"	12 3/8"	72
UL20.1	2" NPT	S/S/BRASS	13 1/2"	8 3/8"	12 3/8"	72
UL21	2" 125# Flg.	S/S	17"	8 3/8"	12 3/8"	74
UL21.1	2" 125# Flg.	S/S/BRASS	17"	8 3/8"	12 3/8"	74
UL22	2" 250# Flg.	S/S	17 1/4"	8 3/8"	12 3/8"	75
UL22.1	2" 250# Flg.	S/S/BRASS	17 1/4"	8 3/8"	12 3/8"	75
UL30	3" NPT	S/S	17 1/4"	10 1/4"	14 3/4"	111
UL30.1	3" NPT	S/S/BRASS	17 1/4"	10 1/4"	14 3/4"	111
UL31	3" 125# Flg.	S/S	20 5/8"	10 1/4"	14 3/4"	131
UL31.1	3" 125# Flg.	S/S/BRASS	20 5/8"	10 1/4"	14 3/4"	131
UL32	3" 250# Flg.	S/S	21"	10 1/4"	14 3/4"	133
UL32.1	3" 250# Flg.	S/S/BRASS	21"	10 1/4"	14 3/4"	133
UL40	4" NPT	S/S	20"	11 3/4"	16 3/4"	163
UL40.1	4" NPT	S/S/BRASS	20"	11 3/4"	16 3/4"	163
UL41	4" 125# Flg.	S/S	23"	11 3/4"	16 3/4"	180
UL41.1	4" 125# Flg.	S/S/BRASS	23"	11 3/4"	16 3/4"	180
UL42	4" 250# Flg.	S/S	23 5/16"	11 3/4"	16 3/4"	183
UL42.1	4" 250# Flg.	S/S/BRASS	23 5/16"	11 3/4"	16 3/4"	183

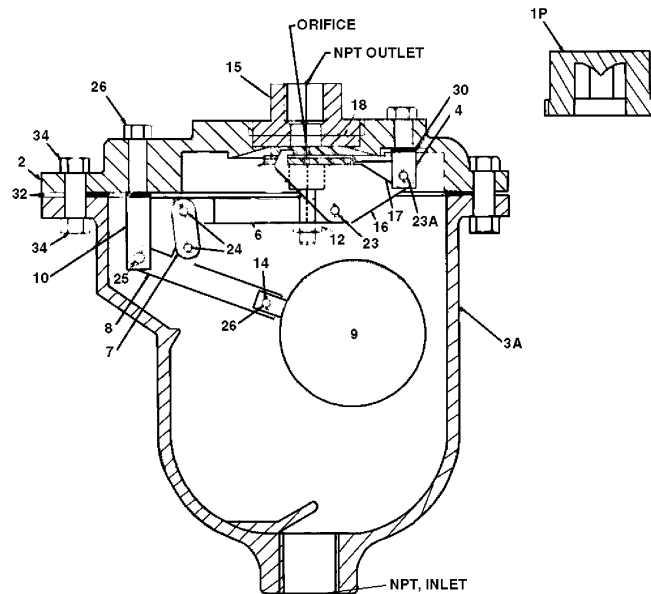

\* The above parts are interchangeable at the customer's request.



# Submittal Sheet for Crispin UL Series

## 1" Universal Air Release Valve

Manufactured in compliance with ANSI/AWWA C512

Date: 2016

### Orifice Options

DIAMETER	MAX. PRESSURE	FLOW RATE
3/16	150 PSIG	54.6 SCFM
3/32	300 PSIG	26.4 SCFM

### Size Specifications

MODEL	INLET SIZE	OUTLET SIZE	A	B	WHT.
UL10	1" NPT	1" NPT	9.75	10.75	27
UL10.1	1" NPT	1" NPT	9.75	10.75	27

### Parts List

ITEM	DESCRIPTION	MATERIAL	ASTM
1S	TOP	CAST IRON	A126 CL.B
2	FLANGE	CAST IRON	A126 CL.B
3	BODY	CAST IRON	A126 CL.B
3W	LOCK WASHER	STAINLESS STEEL	A240
4	AIR & VAC FULCRUM	STAINLESS STEEL	A240
**6	VALVE LEVER	STAINLESS STEEL	A582
7	LINK	STAINLESS STEEL	A240
8	BALL LEVER	STAINLESS STEEL	A240
9	FLOAT	STAIN LESS STEEL	A240
10	BALL FULCRUM	STAINLESS STEEL	A582
11	VALVE PLUNGER	STAINLESS STEEL & BUNA-N RUBBER	A193
12	PLUNGER NUT	STAINLESS STEEL	A194
15	PRESSURE SEAT	STAINLESS STEEL	A582
16	PRESSURE FULCRUM	STAINLESS STEEL	A240
17	SEAT CAGE	STAINLESS STEEL	A240
18	AIR & VAC SEAT	BUNA-N RUBBER	N/A
23	BEARING PIN	STAINLESS STEEL	A582
23A	BEARING PIN	STAINLESS STEEL	A582
24	BEARING PIN	STAINLESS STEEL	A582
25	BEARING PIN	STAINLESS STEEL	A582
26	COTTER PIN	STAINLESS STEEL	A313
29	DRAIN PLUG	BRASS	B505
30	FULCRUM WASHER	FIBER	N/A
32	FLANGE GASKET	ARMSTRONG N-8092	N/A
33	FLANGE BOLT	STEEL	A307
34	NUT	STEEL	A563
50	INTERFERENCE PIN	STAINLESS STEEL	A582

\*\* Material for UL10.1 will be brass

**Option:** A protectop will be supplied to prevent debris from entering the outlet of the valve.

**Option:** (Where pressures are greater than 300 PSIG), the valve(s) shall be ANSI Class \_\_\_\_\_ flanged inlet connection, and shall have a (steel, stainless steel, or ductile iron) body, top and inlet flange.

Standard operating pressure for Crispin Air Valves is 20 to 150 PSIG. Please check one of the following if your operating needs differ:  
 \_\_\_\_ 2 to 40 PSIG    \_\_\_\_ 151 to 300 PSIG

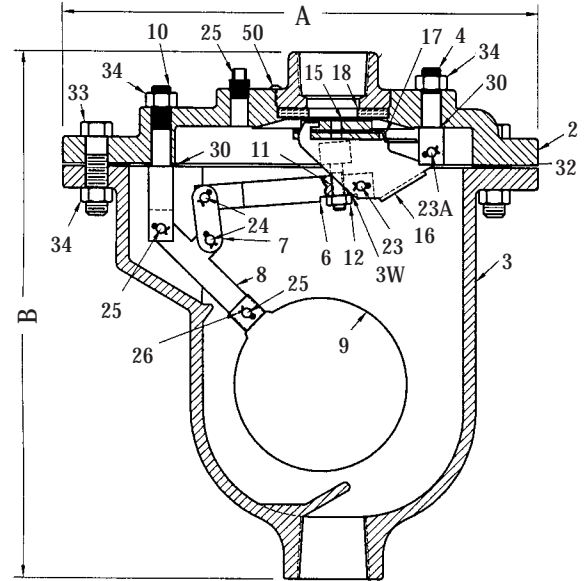

### Specifications

The valve(s) shall be installed at the high points in the system or at points selected by the engineer. This will permit discharging the surge of air from an empty line when filling, and relieve the vacuum when draining the system. The valve(s) shall also release an accumulation of air when the system is under pressure. This shall be accomplished in a single valve body.

The valve(s) shall operate through a compound lever system which will seal both the pressure orifice and the air and vacuum orifice simultaneously. This lever system shall permit a \_\_\_\_\_" orifice to release an accumulation of air from the valve body at a capacity of \_\_\_\_\_ SCFM of air and pressure of \_\_\_\_\_ PSIG.

The function of the lever system shall also permit a positive disengagement of the main valve from the large orifice, as the float drops and pressure decreases. The disengagement shall be immediate and not limited to the initial draw of a vacuum.

The valve(s) shall be Crispin Model \_\_\_\_\_ Universal Air Valve as manufactured by Multiplex Manufacturing Co., Berwick, PA. The valve(s) shall be \_\_\_\_\_" NPT screwed or ANSI Class (125, 250) flanged inlet connection, and shall have a cast iron body, top and inlet flange (where required), stainless steel float and trim with Buna-N seat. Valves which operate the pressure plunger via a single lever and fulcrum will not be acceptable.

SUBMITTAL SHEET FOR UL SERIES

# Submittal Sheet for Crispin UL Series



## 2" Universal Air Release Valve

Manufactured in compliance with ANSI/AWWA C512

Date: 2016

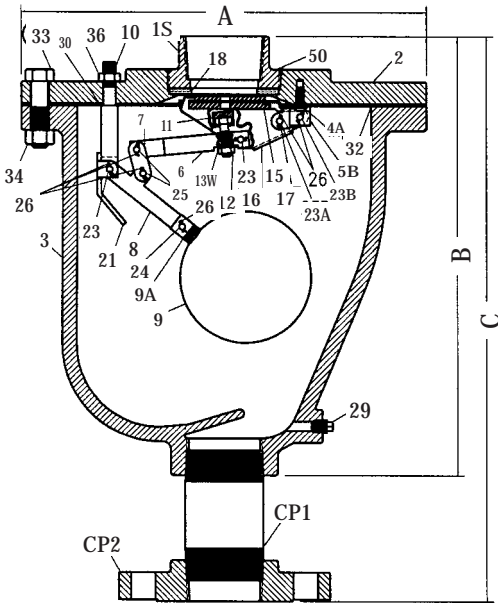

### Specifications

The valve(s) shall be installed at the high points in the system or at points selected by the engineer. This will permit discharging the surge of air from an empty line when filling, and relieve the vacuum when draining the system. The valve(s) shall also release an accumulation of air when the system is under pressure. This shall be accomplished in a single valve body.

The valve(s) shall operate through a compound lever system which will seal both the pressure orifice and the air and vacuum orifice simultaneously. This lever system shall permit a \_\_\_\_\_" orifice to release an accumulation of air from the valve body at a capacity of \_\_\_\_\_ SCFM of air and pressure of \_\_\_\_\_ PSIG.

The function of the lever system shall also permit a positive disengagement of the main valve from the large orifice, as the float drops and pressure decreases. The disengagement shall be immediate and not limited to the initial draw of a vacuum.

The valve(s) shall be Crispin Model \_\_\_\_\_ Universal Air Valve as manufactured by Multiplex Manufacturing Co., Berwick, PA. The valve(s) shall be \_\_\_\_\_" NPT screwed or ANSI Class (125, 250) flanged inlet connection, and shall have a cast iron body, top and inlet flange (where required), stainless steel float and trim with Buna-N seat. Valves which operate the pressure plunger via a single lever and fulcrum will not be acceptable.

**Option:** A protectop will be supplied to prevent debris from entering the outlet of the valve.

**Option:** (Where pressures are greater than 300 PSIG), the valve(s) shall be ANSI Class \_\_\_\_\_ flanged inlet connection, and shall have a (steel, stainless steel, or ductile iron) body, top and inlet flange. All Crispin Valves are hydrostatically tested at 150% of their maximum working pressure. Standard operating pressure for Crispin Air Valves is 20 to 150 PSIG. Please check one of the following if your operating needs differ: \_\_\_\_\_ 2 to 40 PSIG \_\_\_\_\_ 151 to 300 PSIG

### Orifice Options

DIAMETER	MAX. PRESSURE	DISCHARGE RATE
1/4"	150 PSIG	98 SCFM
3/16"	250 PSIG	88 SCFM
1/8"	300 PSIG	46.7 SCFM

### Size Specifications

MODEL	INLET SIZE	OUTLET SIZE	A	B	C	WHT.
UL20	2" NPT	2" NPT	12.50	13.50		72
UL20.1	2" NPT	2" NPT	12.50	13.50		72
*UL21	2" 125# FLG	2" NPT	12.50		17.00	78
UL21.1	2" 125# FLG	2" NPT	12.50		17.00	78
UL22	2" 250# FLG	2" NPT	12.50		17.25	89
UL22.1	2" 250# FLG	2" NPT	12.50		17.25	89

\* Includes ANSI Class 125 or 250 Companion FLG and NPL

### Parts List

ITEM	DESCRIPTION	MATERIAL	ASTM
1S	TOP	CAST IRON	A126 CL.B
2	FLANGE	CAST IRON	A126 CL.B
3	BODY	CAST IRON	A126 CL.B
4A	CAP SCREW	STAINLESS STEEL	A193
5B	AIR & VAC FULCRUM	STAINLESS STEEL	A240
**6	VALVE LEVER	STAINLESS STEEL	A582
7	LINK	STAINLESS STEEL	A240
8	BALL LEVER	STAINLESS STEEL	A240
9	FLOAT	STAINLESS STEEL	A240
9A	FLOAT ROD	STAINLESS STEEL	A582
10	BALL FULCRUM	STAINLESS STEEL	A582
11	VALVE PLUNGER	STAINLESS STEEL & BUNA-N RUBBER	A193
12	PLUNGER NUT	STAINLESS STEEL	A194
13W	LOCK WASHER	STAINLESS STEEL	A240
15	PRESSURE SEAT	STAINLESS STEEL	A582
16	PRESSURE FULCRUM	STAINLESS STEEL	A240
17	SEAT CAGE	STAINLESS STEEL	A240
18	AIR & VAC SEAT	BUNA-N RUBBER	N/A
21	PRESSURE LIMIT STOP	STAINLESS STEEL	A240
23	BEARING PIN	STAINLESS STEEL	A582
23A	BEARING PIN	STAINLESS STEEL	A582
23B	BEARING PIN	STAINLESS STEEL	A582
24	BEARING PIN	STAINLESS STEEL	A582
25	BEARING PIN	STAINLESS STEEL	A582
26	COTTER PIN	STAINLESS STEEL	A313
29	DRAIN PLUG	BRASS	B505
30	FULCRUM WASHER	FIBER	D710
32	FLANGE GASKET	ARMSTRONG N-8092	N/A
33	FLANGE BOLT	STEEL	A307
34	NUT	STEEL	A563
36	BALL FULCRUM NUT	STEEL	A563
50	INTERFERENCE PIN	STAINLESS STEEL	A582

### FLANGE CONNECTION PARTS

CP1	NIPPLE	STEEL	A53
CP2	COMPANION FLANGE	CAST IRON	A126 CL. B

\*\* Material for UL20.1 valve lever will be brass



# Submittal Sheet for Crispin UL Series

## 3"–4" Universal Air Release Valve

Manufactured in compliance with ANSI/AWWA C512

Date: 2016

### Orifice Options

DIAMETER	MAX. PRESSURE	DISCHARGE RATE
1/4"	150 PSIG	98 SCFM
3/16"	250 PSIG	88 SCFM
1/8"	300 PSIG	46.7 SCFM

### Size Specifications

MODEL	INLET SIZE	OUTLET SIZE	A	B	C	WHT.
UL30	3"NPT	3" NPT	14.75	18.00		114
UL31	3" 125# FLG	3" NPT	14.75		20.50	125
UL32	3" 250# FLG	3" NPT	14.75		21.00	131
UL30.1	3" NPT	3" NPT	14.75	18.00		114
UL31.1	3" 125# FLG	3" NPT	14.75		20.50	125
UL32.1	3" 250# FLG	3" NPT	14.75		21.00	131
UL40	4" NPT	4" NPT	16.75	20.00		162
UL41	4" 125# FLG	4" NPT	16.75		23.00	177
UL42	4" 250# FLG	4" NPT	16.75		23.25	188
UL40.1	4" NPT	4" NPT	16.75	20.00		162
UL41.1	4" 125# FLG	4" NPT	16.75		23.00	177
UL42.1	4" 250# FLG	4" NPT	16.75		23.25	188

### Parts List

ITEM	DESCRIPTION	MATERIAL	ASTM
1S	TOP	CAST IRON	A126 CLB
2	FLANGE	CAST IRON	A126 CLB
3	BODY	CAST IRON	A126 CLB
4	AIR/VAC FULCRUM	STAINLESS STEEL	A240
4A	FULCRUM BOLT	STAINLESS STEEL	A193
5	PRESSURE FULCRUM	STAINLESS STEEL	A240
**6	VALVE LEVER	STAINLESS STEEL	A582
7	LINK	STAINLESS STEEL	A240
8	BALL LEVER	STAINLESS STEEL	A240
9	FLOAT	STAINLESS STEEL	A240
9A	FLOAT ROD	STAINLESS STEEL	A582
10	BALL FULCRUM	STAINLESS STEEL	A582
11	VALVE PLUNGER	STAINLESS STEEL& BUNA-N RUBBER	A193/D2000
12	PLUNGER NUT	STAINLESS STEEL	A194
13W	LOCK WASHER	STAINLESS STEEL	A240
15	PRESSURE SEAT	STAINLESS STEEL	A582
17	SEAT CAGE	STAINLESS STEEL	A240
18	AIR & VAC SEAT	BUNA-N RUBBER	D2000
21	PRESSURE LIMIT STOP	STAINLESS STEEL	A240
23	BEARING PIN	STAINLESS STEEL	A582
23A	BEARING PIN	STAINLESS STEEL	A582
24	BEARING PIN	STAINLESS STEEL	A582
25	BEARING PIN	STAINLESS STEEL	A582
26	COTTER PIN	STAINLESS STEEL	A313
29	DRAIN PLUG	BRASS	B505
30	FULCRUM WASHER	FIBER	D710
31	FULCRUM WASHER	FIBER	D710
31A	FULCRUM WASHER	FIBER	D710
32	FLANGE GASKET	ARMSTRONG N-8092	N/A
33	FLANGE BOLT	STEEL	A307
34	NUT	STEEL	A563
35	AIR/VAC FULCRUM NUT	STEEL	A563
36	BALL FULCRUMNUT	STEEL	A563
37	ADJUSTING PLATE	STAINLESS STEEL	A240
38	BOLT	STAINLESS STEEL	A193
50	INTERFERENCE PIN	STAINLESS STEEL	A582

\*\* Material for UL30.1, UL31.1, UL40.1, UL41.1, UL42.1 will be brass

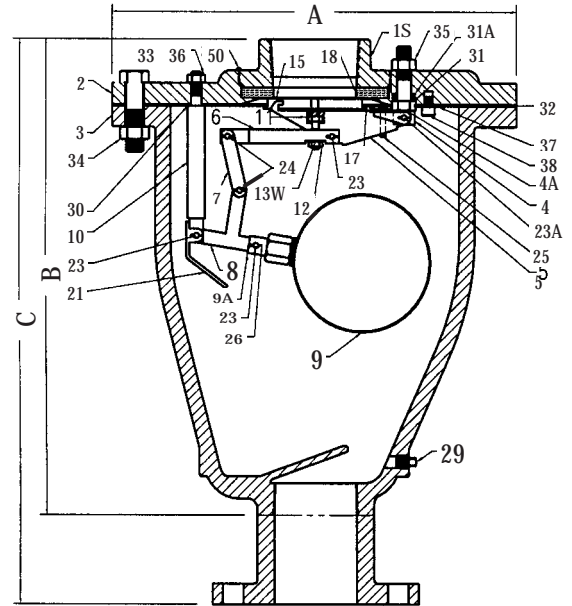

### Specifications

The valve(s) shall be installed at the high points in the system or at points selected by the engineer. This will permit discharging the surge of air from an empty line when filling, and relieve the vacuum when draining the system. The valve(s) shall also release an accumulation of air when the system is under pressure. This shall be accomplished in a single valve body.

The valve(s) shall operate through a compound lever system which will seal both the pressure orifice and the air and vacuum orifice simultaneously. This lever system shall permit a \_\_\_\_\_" orifice to release an accumulation of air from the valve body at a capacity of \_\_\_\_\_ SCFM of air and pressure of \_\_\_\_\_ PSIG.

The function of the lever system shall also permit a positive disengagement of the main valve from the large orifice, as the float drops and pressure decreases. The disengagement shall be immediate and not limited to the initial draw of a vacuum.

The valve(s) shall be Crispin Model \_\_\_\_\_ Universal Air Valve as manufactured by Crispin-Multiplex Manufacturing Co., Berwick, PA. The valve(s) shall be \_\_\_\_\_" NPT screwed or ANSI Class (125, 250) flanged inlet connection, and shall have a cast iron body, top and inlet flange (where required), stainless steel float and trim with Buna-N seat. Valves which operate the pressure plunger via a single lever and fulcrum will not be acceptable.

**Option:** A protectop will be supplied to prevent debris from entering the outlet of the valve.

**Option:** (Where pressures are greater than 300 PSIG), the valve(s) shall be ANSI Class \_\_\_\_\_ flanged inlet connection, and shall have a (steel, stainless steel, or ductile iron) body, top and inlet flange.

Standard operating pressure for Crispin Air Valves is 20 to 150 PSIG. Please check one of the following if your operating needs differ:  
 \_\_\_\_\_ 2 to 40 PSIG    \_\_\_\_\_ 151 to 300 PSIG

SUBMITTAL SHEET FOR UL SERIES