

Wafer Check Valve

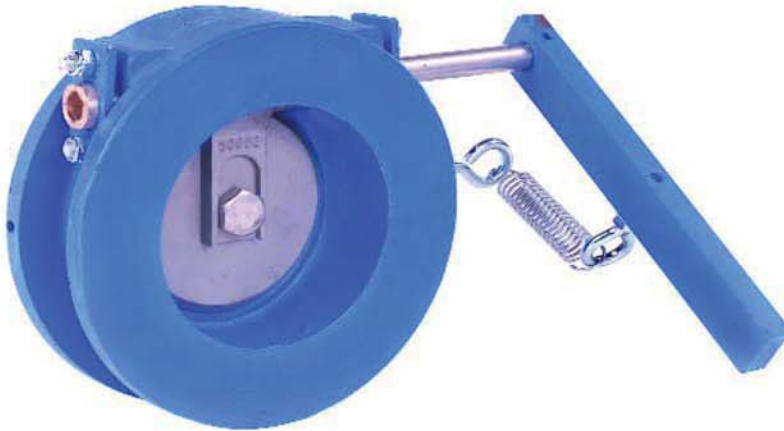

- Narrow Face-to-Face
- Heavy Duty Cast Iron Body
- 316 Stainless Steel Internals
- Spring Assisted Closure
- Reversible Spring Arm Assembly
- Elastomer Seat in Body
- Unobstructed Round Port
- Disc Position Indicator
- Manual Override Lever
- Economical Alternative

SCOPE OF THE LINE: WAFER CHECK VALVE

Sizes

3" - 12"

Body

The compact wafer body is constructed of ASTM A-126 Class B cast iron. This short face-to-face dimension means less space is required than with traditional flanged swing check valves.

Seat

Numerous "O" ring seat materials are available. Positive retention of the seat is accomplished by the dovetail groove machined in the valve body. This groove reduces the possibility of the "O" ring being displaced from the body while allowing removal and replacement during maintenance.

Packing

Split rings of PTFE packing are employed to prevent leakage through the shaft.

Shaft / Bushings

The one piece 316 stainless steel shaft is supported by two (2) bronze bushings to insure proper alignment of the disc and seat. The design allows the shaft/arm to be field changed to either left or right hand positions.

Disc

A corrosion resistant 316 stainless steel disc is used to reduce the chance of disc failure. Precision machining of the mating surface provides uniform contact between the disc and seat.

Disc Arm

Continuing the concept of 316 stainless steel internals the disc arm is manufactured of 316 stainless steel. The arm is attached to the disc and shaft by use of stainless steel fasteners.

Spring / Arm Assembly

The spring arm assembly provides both positive indication of the disc position as well as serving as a manual override for use in back flushing the system. The spring allows the valve to operate properly even if installed in a vertical line. The spring also permits a predetermined line pressure to be reached prior to the valve opening.

Flow

Round unobstructed ports translate to higher flow capabilities than are possible with other types of wafer check valves.

WAFER CHECK VALVE: TECHNICAL SPECIFICATIONS

General

Check valve shall be of the short face-to-face type with external spring to ensure tight shutoff. The pressure rating shall be 200 psi.

Valve Bodies

Valve bodies shall be of ASTM A-126 Class B cast iron. Disc and disc arm shall be of ASTM A-743 Grade CF8M stainless steel.

Valve Shaft

The valve shaft shall be manufactured of ASTM A-276 Grade 316 stainless steel and supported by two (2) SAE 660 bronze bearings. Shaft sealing shall be accomplished by multiple rings of braided PTFE Teflon rings. Packing shall be utilized on each side of the valve.

Arm Assembly

The design of the valve shall be such that spring/arm assembly can be field changed from right to left. The closure spring shall be manufactured of ASTM A-228 spring steel. The spring arm shall be constructed of carbon steel ASTM A-36 and designed to provide disc position indication. The spring arm shall be capable of overriding the spring action for use as an override lever.

Valve Seat

The valve seat shall be of specified O-ring material and retained in a dovetail groove in the valve body.

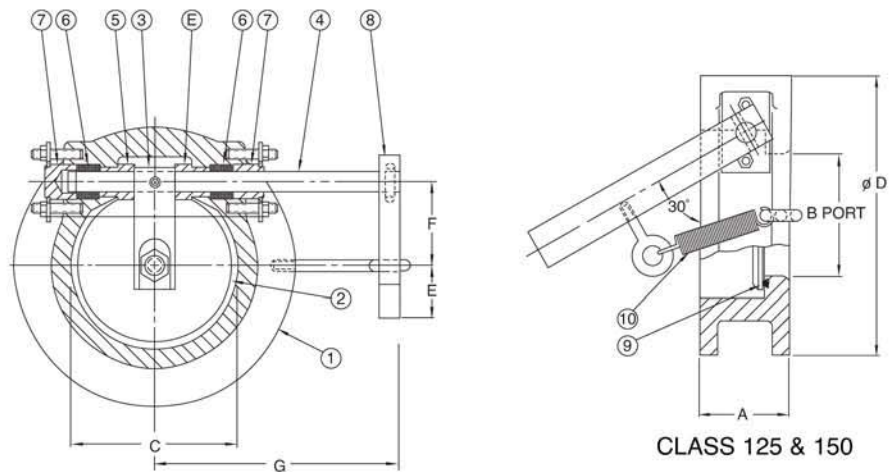

MATERIALS OF CONSTRUCTION

ITEM	COMPONENT	MATERIAL	SPECIFICATION
1	BODY	*CAST IRON	ASTM A-126 CL B
2	DISC	STAINLESS STEEL	ASTM A-743 CF8M
3	DISC ARM	STAINLESS STEEL	ASTM A-743 CF8M
4	SHAFT	STAINLESS STEEL	ASTM A-276 GR 316
5	BUSHINGS	BRONZE	SAE 660
6	PACKING	BRAIDED PTFE	TEFLON
7	PACKING GLAND	BRONZE	SAE 660
8	SPRING ARM	CARBON STEEL	ASTM A-36
9	SEAT	ELASTOMER	AS SPECIFIED
10	SPRING	SPRING STEEL	ASTM A-228

*CLASS 150 BODY MATERIAL IS ASTM A-536

SIZE	A	B	C	D	E	F	H	WEIGHT
3	3.75	2.06	2.63	5.25	1.50	2.13	5.00	13
4	2.25	3.03	3.63	6.88	2.63	2.13	6.00	18
6	2.75	4.75	5.44	8.75	1.00	3.25	7.13	27
8	2.88	6.44	7.25	11.00	1.38	4.00	8.06	42
10	3.13	7.63	8.50	13.13	4.63	4.88	9.50	63
12	3.50	9.50	10.44	16.13	4.38	5.88	10.81	96